



FIFE GUIDING SOLUTIONS

Advanced Guiding Systems for Web Handling

MAXCESS

Sensors



Unwind/Rewind Stands



Actuators



Guides



Controllers

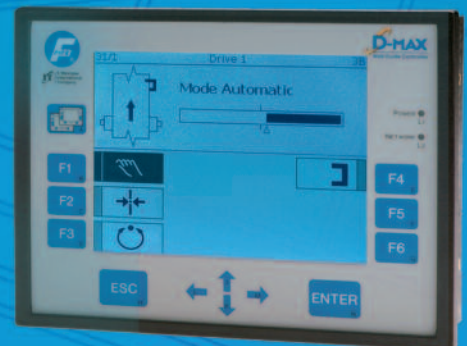

Worldwide Presence

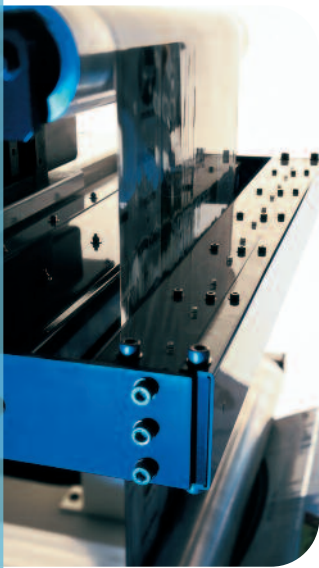

Fife prides itself on knowledgeable support and service that begins with the internal sales staff and continues beyond installation. With over 50 salespeople worldwide and operations throughout North America, South America, Europe and Asia, Fife can deliver faster, more responsive service than other guiding suppliers. Fife sales and service personnel are

factory-trained in various service disciplines including applications analysis, design and engineering. This large, reliable service team is dedicated to providing solutions specifically designed for your applications.

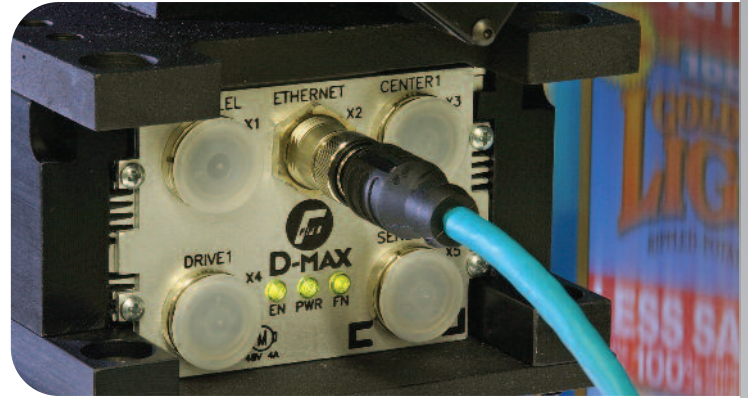

Application Expertise

With more guiding installations in the market, our industry knowledge is unsurpassed. Our highly trained Technical Service and Field Sales Engineers will work closely with you to identify the guiding solution that is right for your process line.

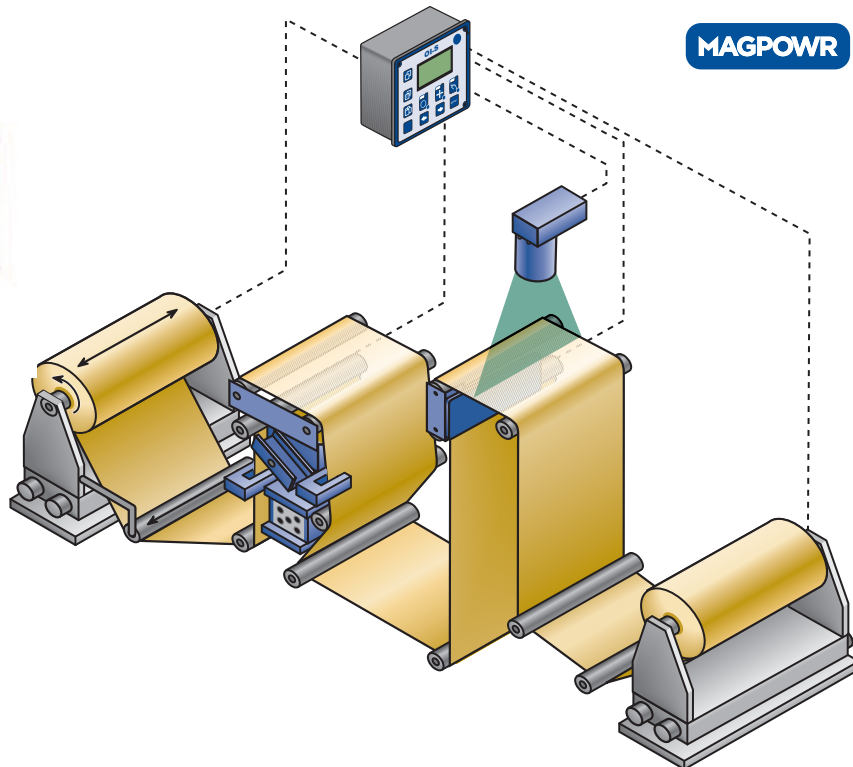

Web Guide Controllers

The web guide controller is the heart of the electronic guiding system. Fife CE-compliant controllers provide the control you need to operate effectively and efficiently. When combined with appropriate sensors, actuators and guiding equipment, Fife controllers provide a highly accurate, Type I, proportional, closed-loop servo system with a high dynamic response to the running web.

D-MAX™ Series Web Guide Systems

- A complete system of powerful modular components to improve efficiency and roll quality
- Modular design is available as a pre-wired system or feature-rich, stand-alone components
- Low-profile controller provides the highest levels of guiding accuracy and powerful options like high-speed networking and remote system monitoring
- Operator Interface displays graphics and speaks your language to simplify setup and operation



Polaris™ DP-20 Web Guide Controller

- Precise web guide control that's easy to set up and operate
- Small form factor 144 x 144 x 103 mm (5.67 x 5.67 x 4.06 inches) is easily integrated into machine panel
- Intuitive setup and user-friendly operation reduces downtime between runs
- High dynamic response ensures consistent, high quality rolls



All controllers are UL 61010 and CE compliant.

Polaris™ DP-30 Web Guide Controller

- Same form and fit as CDP-01 single-drive, with improved functionality
- Easy drop-in replacement for CDP-01 Controllers
- Ability to drive up to 2.6 amp motor
- Universal power supply (90-264 VAC)
- Backlit display

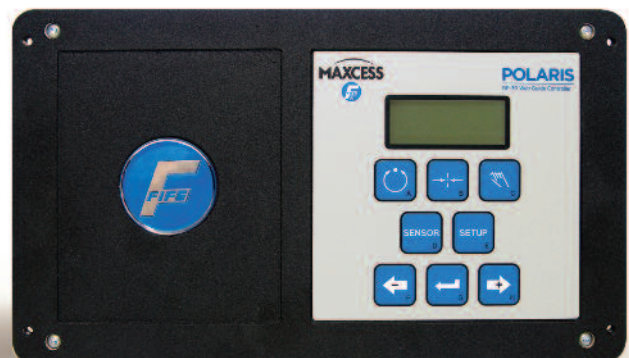

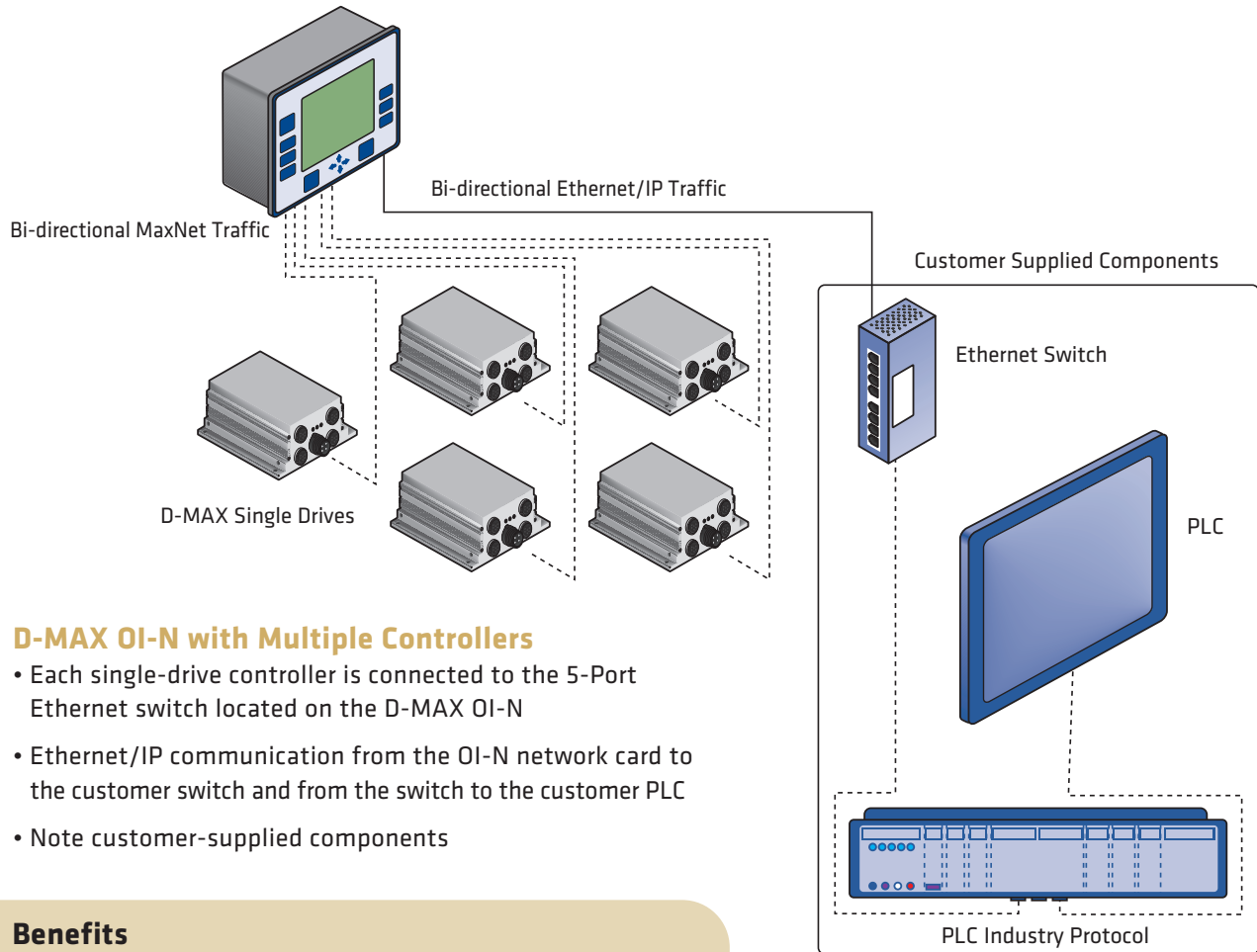

D-MAX OI-N with Multiple Controllers

- Each single-drive controller is connected to the 5-Port Ethernet switch located on the D-MAX OI-N
- Ethernet/IP communication from the OI-N network card to the customer switch and from the switch to the customer PLC
- Note customer-supplied components

Benefits

- D-MAX OI-N is utilized as the network gateway to the customer PLC
- Multiple controllers being controlled by a single Operator Interface (OI)

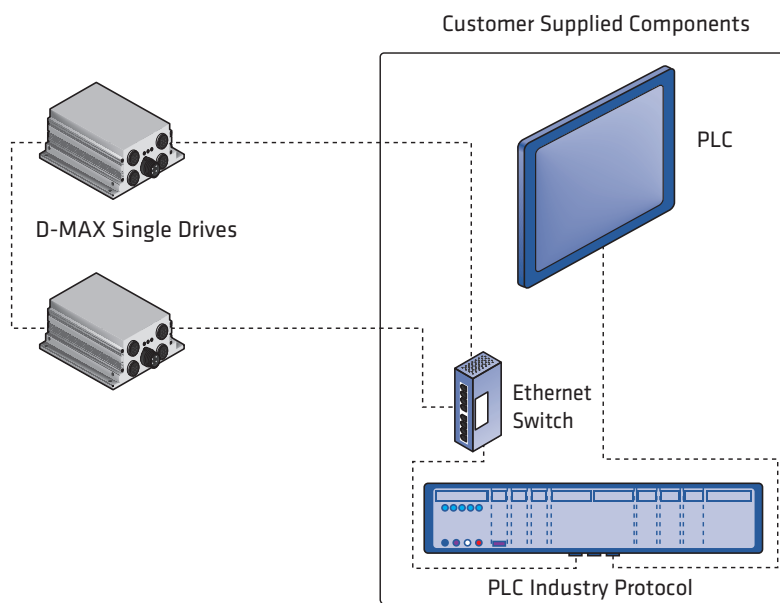

D-MAX Controllers with Embedded Ethernet/IP

- Single- or dual-drive controllers with embedded Ethernet/IP activated
- Bi-directional Ethernet/IP traffic from D-MAX Controller to customer switch/PLC
- Maximum number of D-MAX devices with real-time information is 32 single or dual-drive controllers
- Note that customer is responsible for PLC code development, run screen, setup screen, alarm screen

Benefits

The D-MAX single- or dual-drive controller with embedded Ethernet/IP allows machine builders the opportunity to reduce overall cost when using a PLC with Ethernet/IP communication



FIFE-500 Guide for Narrow Web Application

This guiding system is easy to use and install, while using new technology to help you improve efficiency. The FIFE-500 features icons and text in multiple languages to simplify operation and reduce the time necessary for training.

- Color touch screen is detachable and rotates 90°
- Compact design
- Brushless motor
- 13 languages and icons for easy setup and operation
- Splice table
- Fine adjustment

Specifications

- Web widths up to 510 mm (20 inches)
- Tension up to 355 N (80 lbs)
- 24 VDC ± 25%, 108 watt
- CE and UL

FIFE-500 Splice Table

- Optional splice table configuration

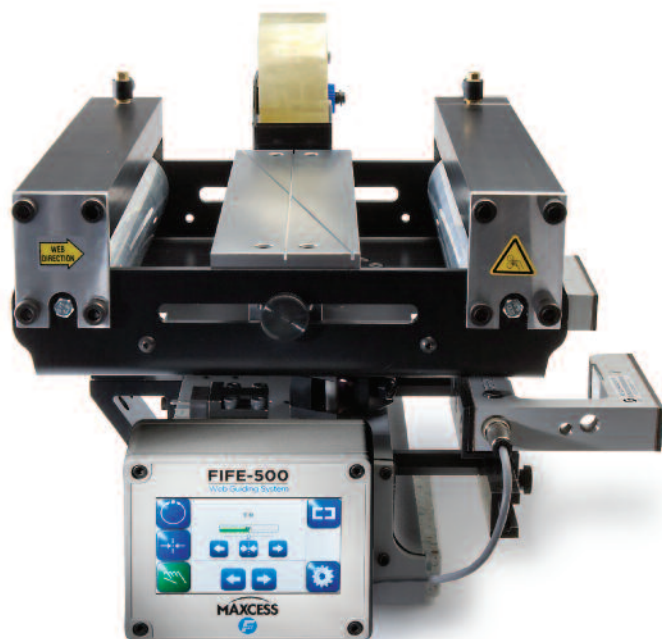

Wide Band Sensors

Fife's complete family of sensors and positioners to accommodate a variety of materials and variations in web width started over 40 years ago with the first sensor to span the entire width of the web, the SE-4000. In the 1990s, the Lazer*Wide sensor simplified routine maintenance and, in 2011, the DAC-005 Diode Array Camera added Web Width Measurement. Coupled with a full line of sensor positioners, Fife wide band sensors are a simple way to increase accuracy in web alignment. The newest addition to the family, TruWide uses the latest technology to improve accuracy, simplify maintenance, provide web width measurement and reduce cost.

Positioners

The remote positioning of sensors is another way to save time, reduce waste, improve accuracy and eliminate potential injuries. Fife positioners feature a dust-proof design that is virtually maintenance-free.

TruWide SE-45 Ultrasonic Sensor

- Either edge and web width detection in analog mode
- Multiple web and web width detection in digital (Ethernet) mode
- Efficient maintenance – transducers can be replaced independently

Sensor Positioners

Pro-Trac for edge or center guiding applications

- Model 100 is a low-cost, self-contained positioner with display and motor controls combined for easy installation

- Model 200 is a heavy-duty positioner designed for continuous operation in chasing systems, moving-sensor center guide systems, web width measurement systems or simple sensor positioning

M-23 Oscillator for winding or guiding applications

- Used to unwind uniform staggered rolls, avoiding rippled material and non-cylindrical rolls due to caliper variation
- Provides complete, independent control of oscillation magnitude and rate
- Sensor position is variable to accommodate changes in web width

Electromechanical or Hydraulic Positioners for chasing applications

- EM-8 - Durable positioner capable of handling loads up to 568 kg (1,252 lbs) and strokes from 51 to 152 mm (2 to 6 inches)
- EM-11 - Dual-sensor positioner with placement up to 1,524 mm (60 inches) apart and strokes up to 406 mm (16 inches)

M-12 Manual Positioner for center guiding applications

- Dual-sensor positioning for most fixed-sensor center guiding applications
- Capable of handling up to 1,626 mm (64 inches) web width variations
- Position indicating handwheel provides simple, accurate operation



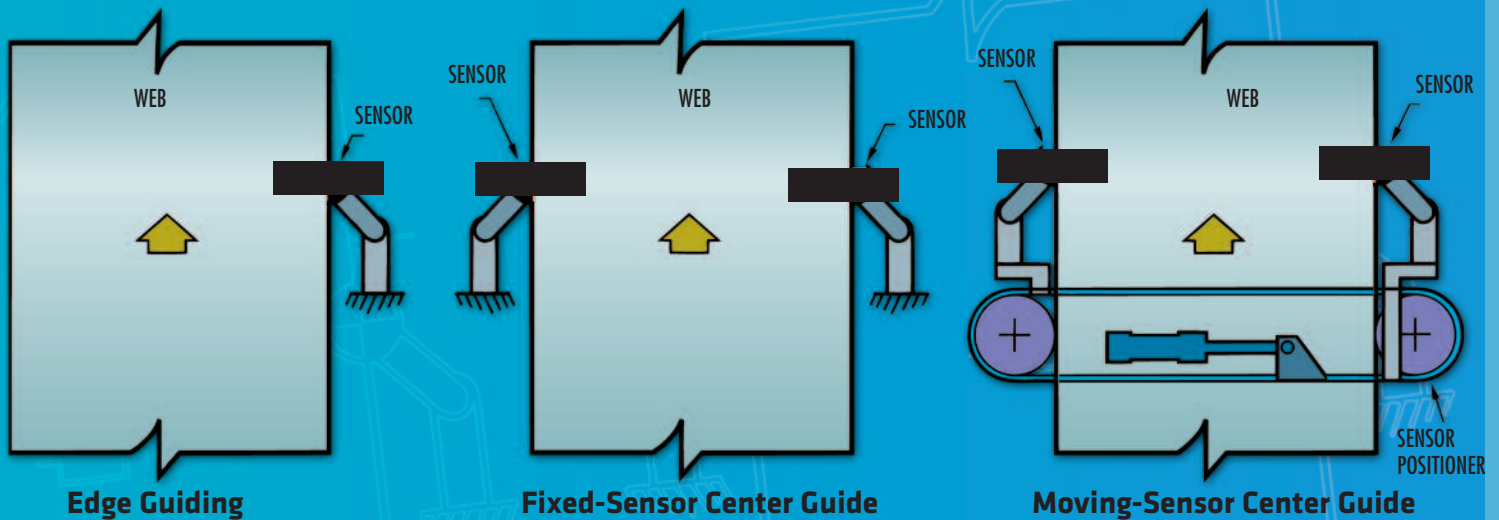

Sensors

One size does not fit all. For that very reason, Fife develops sensors to suit any guiding application. Our versatile line of sensors can accommodate edge guiding, line/pattern guiding or center guiding (fixed or moving) in any type of environment and, more importantly, for any type of material.

Infrared

- For single-edge or center guiding applications
- Very versatile, widely used on opaque materials
- Also used on materials with opacity as low as 10%
- Best cost solution for most applications
- Proportional band range from 5.08 to 160.02 mm (0.2 to 6.3 inches) provides accuracy for varying web widths
- Sensor gap of 25 mm (1 inch) and larger

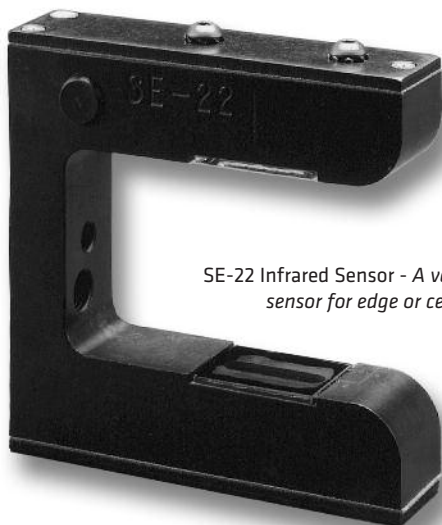

SE-22 Infrared Sensor - A versatile, lightweight sensor for edge or center guiding



SE-38 First*Edge Sensor Advanced technology for materials with varying opacity (down to 0.4 oz/sq yard spunbond)

Pneumatic

- For edge and center guiding in a variety of web widths
- An intrinsically safe component
- Will sense any material opacity - 0 to 100%
- Fife's unique pneumatic design is virtually maintenance-free

Line Guide

- Capable of detecting line, line edge and patterns such as bar codes
- Compatible with the popular D-MAX Series Web Guiding System

Use the sensor selection chart on page 13 to find the sensors that are the best fit for your application.

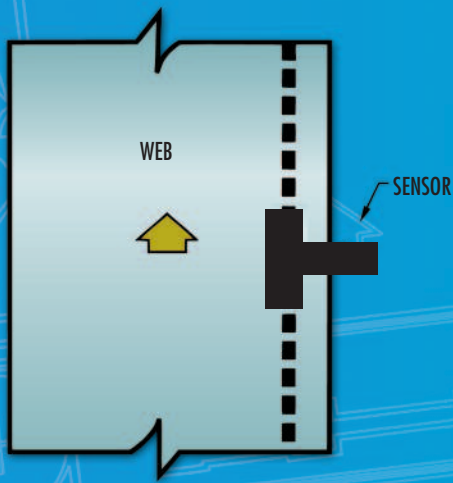

Line or Pattern Guiding

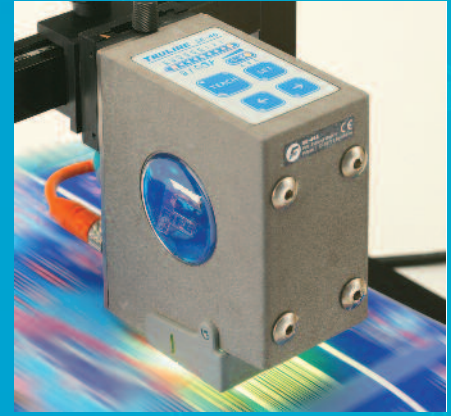

Ultrasonic

- For single-edge or center guiding applications
- UL, cUL and CE certified
- Closed-face design helps with immunity to dust and contaminants
- Ambient shop noises have no effect on Fife's unique ultrasonic technology

Intrinsically Safe

- Single-edge or center guiding in hazardous environments
- Fully certified to Class I, Division 1, Groups C and D hazardous environments
- UL, cUL and CENELEC certified for use throughout Europe and North America

Camera Sensors

- The ideal solution for a wide range of difficult to sense materials from nonwovens to steel
- Highly resistant to contamination, dust particles, oil, vapors and water
- Ideal for armless rewinding, center, edge, line guiding and web width measurement
- Optional LED light



DAC-005 Digital Camera Sensor



SE-34 Lazer*Wide Sensor

Visible Light and Laser

- Single-edge or center guiding and web width measurement
- The most intense, incandescent light bulbs are used to ensure high contrast for maximum guiding accuracy
- Laser-based technology provides flexibility for web width measurement and changes
- Ideal for opaque materials

Special Application Sensors

- Fiber optic sensors
- Capacitance center guide sensor
- Inductive sensors



Actuators

Fife electromechanical actuators are designed to be trouble-free with minimal backlash, producing the highest Dynamic Response in the industry, typically less than 0.051 mm (0.002 inch), for higher accuracy and longer product life. Required application thrust will be a function of total load, coefficient of friction and performance requirements.

Antifriction bearings are currently published with coefficient of friction as low as 0.01. Fife uses a design coefficient of friction of 0.05 to 0.1 to ensure performance through misalignments, contamination, seal drag and acceleration/deceleration factors.

GMA

- Integrated Servo-Center
- Belt-driven actuator with a maximum designed thrust of 2,005 N (451 lbs)
- Maximum shifting speeds of 130 mm/sec (5.12 inches/sec)
- Standard actuator stroke ranges from 25 to 305 mm (1 to 12 inches)

LAB-8

- Belt-driven actuator with a designed thrust from 5,000 to 12,500 N (1,125 to 2,810 lbs)
- Maximum shifting speeds: 27.9 mm/sec (1.1 inch/sec)
- Standard actuator stroke range from 100 to 300 mm (3.94 to 11.81 inches)

LAB-10

- Belt-driven actuator with a designed thrust from 2,002 to 3,558 N (450 to 800 lbs)
- Maximum shifting speeds: 31.75 mm/sec (1.25 inches/sec)
- Standard actuator strokes range from 25 mm to 250 mm (1 to 10 inches) in 25 mm (1 inch) increments

AB-12

- Gear-driven actuator with a designed thrust from 3,914 to 9,341 N (880 to 2,100 lbs)
- Maximum shifting speeds: 26.16 mm/sec (1.03 inches/sec)
- Standard actuator strokes range from 25 to 250 mm (1 to 10 inches) in 25 mm (1 inch) increments, and 305 to 406 mm (12 to 16 inches) in 50 mm (2 inch) increments

LAG-17

- Gear-driven actuator with a designed thrust up to 38,500 N (8,655 lbs)
- Maximum shifting speeds: 67 mm/sec (2.64 inches/sec)
- Standard actuator stroke range from 100 to 600 mm (3.94 to 23.62 inches)



Zero Backlash Actuators

Intermediate Guiding - Displacement-Type

When space is limited, Fife Offset Pivot Guides deliver web/strip position correction with minimal entry and exit span requirements. This type of guide is usually furnished with two rollers. The entire guide pivots to control web position and minimize web stress.

MicroSymat

- Standard roller faces: 80 mm (3.15 inches) and 100 mm (3.94 inches)
- Maximum allowable tension: 100 N (22.5 lbs)

Symat 25/DS-25

- Standard roller faces: 160 mm (6.30 inches), 200 mm (7.88 inches) and 250 mm (9.84 inches)
- Maximum allowable tension: 200 N (45 lbs)

Symat 50/Symat 70G/DS-70

- Standard roller faces: 203 to 610 mm (8 to 24 inches)
- Maximum allowable tension: 623 N (140 lbs)

Symat 120

- Designed to accommodate web widths up to 1,200 mm (47 inches)
- Maximum allowable tension 1,500 N (337 lbs)



LRB

- Designed to accommodate web widths up to 1,930 mm (76 inches)
- Maximum allowable tension: 2,504 N (563 lbs)
- Available for both electromechanical and hydraulic control systems

LRC/Symat 300

- Designed to accommodate large applications
- Available for both electromechanical and hydraulic control systems

All guiding systems are engineered for your specific application. For higher tensions or wider webs contact Fife or your local Field Sales Engineer.

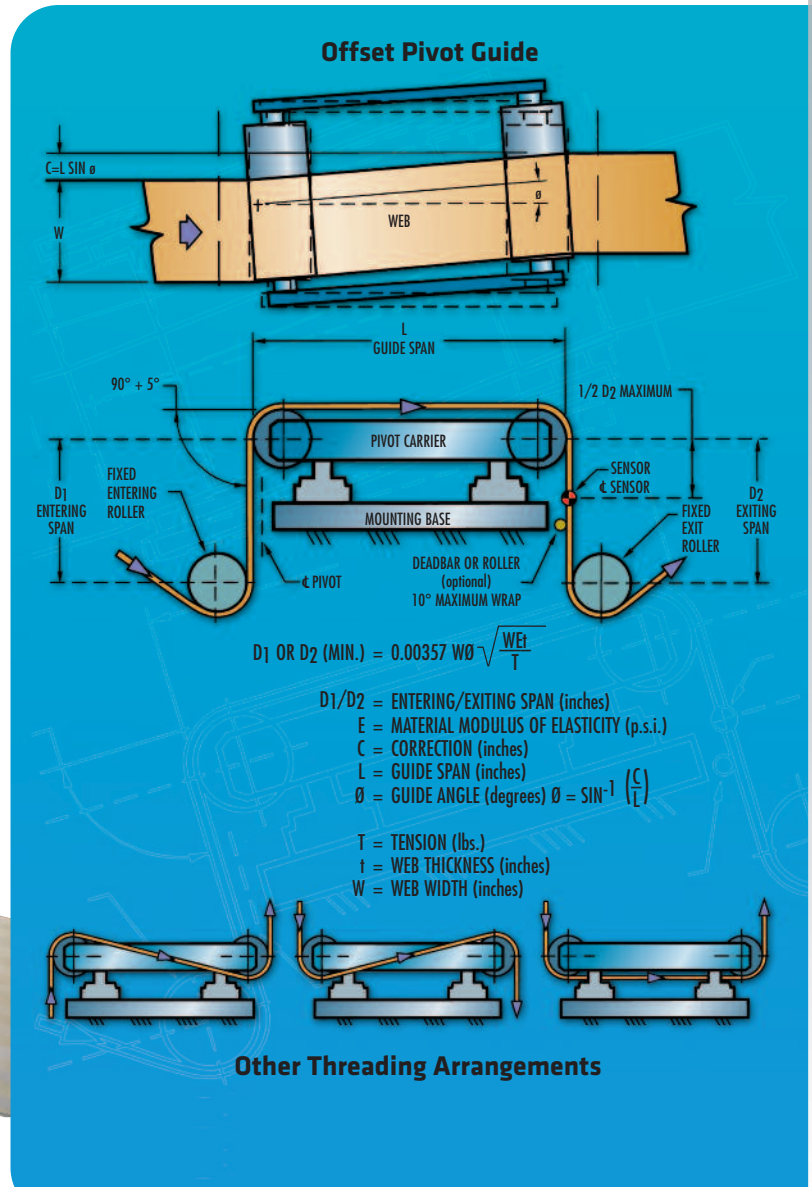

KAMBEROLLER® GUIDE

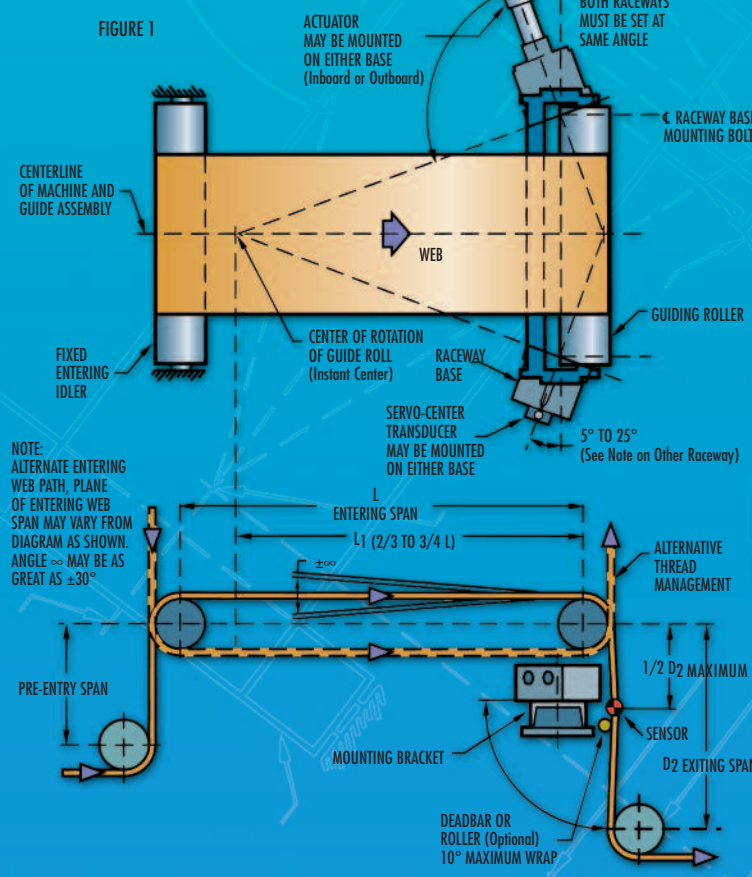

Kamberoller Entry Span Formulas

$$1. C = \frac{9T \left(\frac{L}{W}\right)^2}{tE}$$

$$2. L = \frac{W}{3} \sqrt{\frac{CE}{T}}$$

- C = ± GUIDE CORRECTION (inches)
- E = MATERIAL MODULUS OF ELASTICITY (p.s.i.)
- L = LENGTH OF ENTRY SPAN (inches)
- T = TENSION (lbs.)
- t = MATERIAL THICKNESS (inches)
- W = MATERIAL WIDTH (inches)

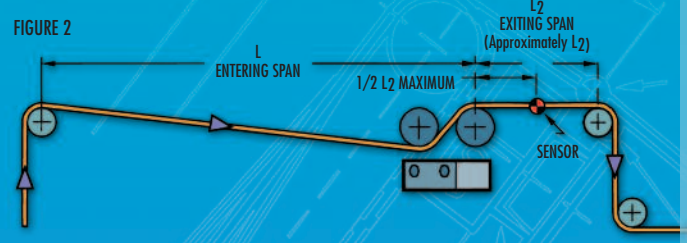

Typical Straight-Through Threading (S-Wrap)

Intermediate Guides - Steering Type

Fife's innovative Steering Guides deliver precise web position by utilizing a long entry span. These versatile guiding assemblies provide immediate lateral correction for transient errors, while at the same time compensating for the web's steady state errors.

Kamberoller® Steering Guide

- Standard roll face lengths range from 381 to 3,048 mm (15 to 120 inches)
- Available for both electromechanical and hydraulic control systems
- Single-, double- or tri-roller arrangements available

Kantiroller Steering Guide

- Versatile guide ideal for applications such as envelope machines and label presses
- Accommodates web widths from less than 203 to 356 mm (8 to 14 inches)
- Single-, double- or tri-roller arrangements available
- Available for both electromechanical and hydraulic control systems

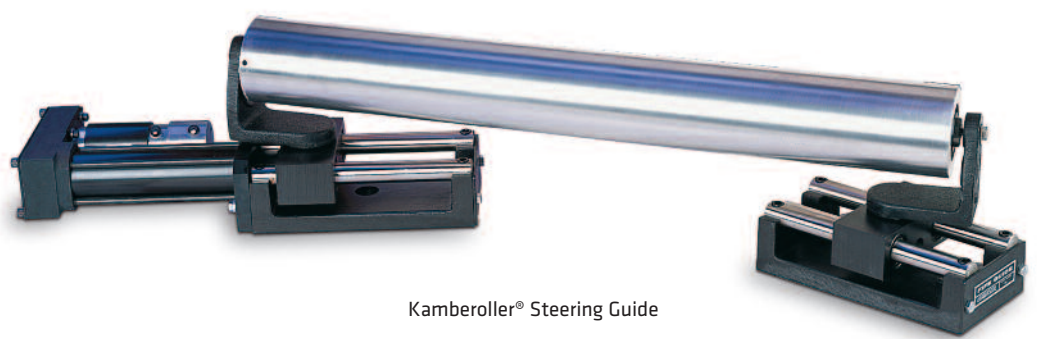

Kamberoller® Steering Guide



Unwind/Rewind Guides

A typical unwind or rewind system consists of an actuator to move the roll laterally, a sensor and a controller. In some cases, however, traditional guiding systems will not work. If a suitable roll stand is not available, Fife will provide the Shifta-Roll Positioning Stand. Powered by either electromechanical or hydraulic actuators, these durable stands are capable of handling loads up to 4,536 kg (10,000 lbs).

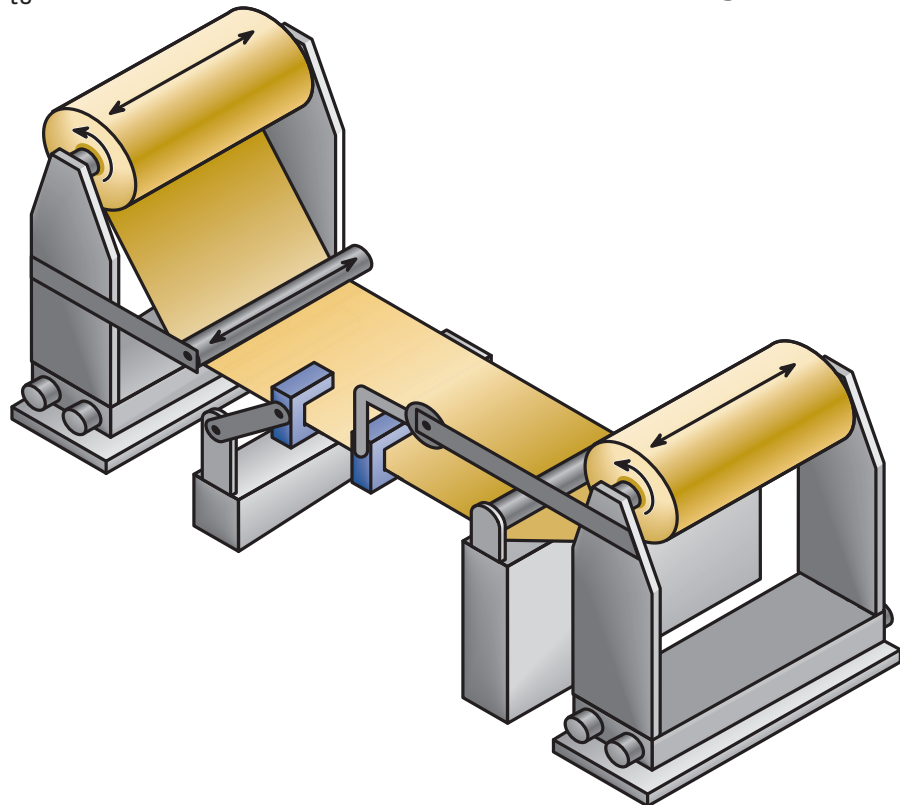

Shifta-Roll Positioning Stands

Unwind Stands

- Roll stands shift laterally to compensate for web misalignment
- May require a directly mounted or slaved idler
- Easily adapts to existing assemblies

Rewind Stands

- Roll stands shift laterally to align with the edge of the approaching web
- Helps to prevent telescoping, ensuring evenly wound rolls
- Easily adapts to existing assemblies

SRS-Type Unwind Stands

- Specifically designed to accommodate large polyethylene rolls used in making bags
- Two-high, light-duty roll design allows one roll to be loaded while the other roll is being used
- Includes roll shafts and drag brakes

POWER UNITS

Regardless of the type of control system you choose, Fife power units are versatile enough to accommodate almost any web material and load requirement.

- For Electrohydraulic or Pneumohydraulic guiding systems with large unwind/rewind loads
- Compact, modular construction is completely self-contained
- Virtually maintenance-free



GUIDING CONTROLS

Smooth, efficient web handling operations begin with the right guiding control system. Fife offers a full line of automatic controls designed to deliver precise, dependable performance, and flexibility to upgrade your operations in the future.

Types of Automatic Guiding Control Systems

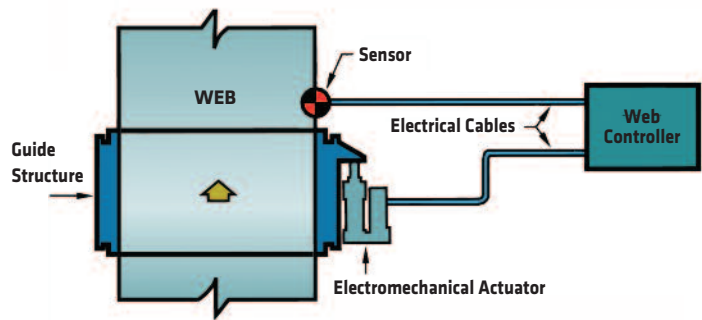

Electromechanical

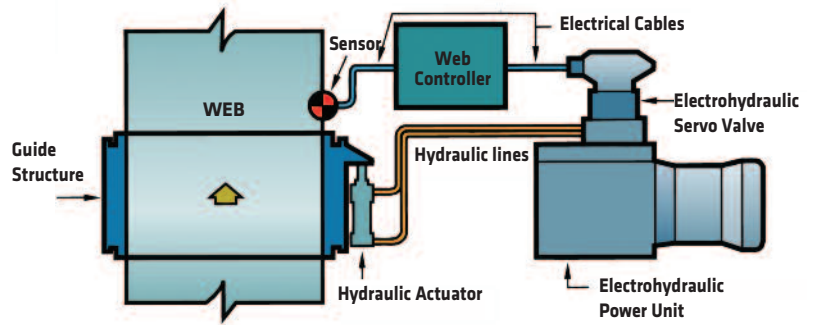

Electrohydraulic

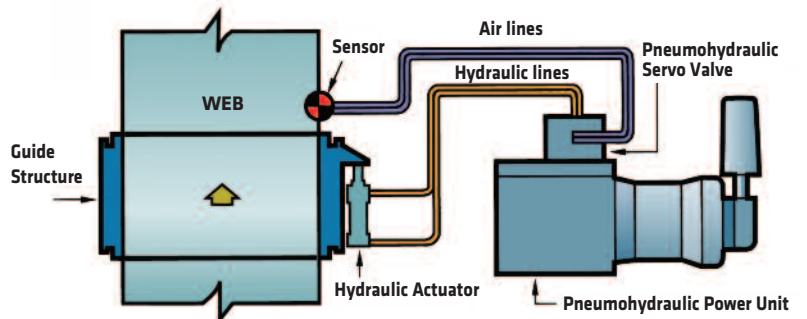

Pneumohydraulic

One size does not fit all. For that very reason, Fife has and will continue to develop sensors that meet the needs of nearly any guiding application. Use this chart to find the Fife sensor that best suits your application needs. For assistance, please call your local support team (listed on the back cover) or visit www.maxcessintl.com.

	Opaque					Transparent			Woven		Nonwoven			Carpet		
	Paper	Colored Film	Foil	Felt	Opaque & Transparent	Film	Line Guide	Irregular Edge	Cloth	Window Screen	Gauze	Spunbond	Tire Cord	Roofing	Tuft	Scrim
Infrared Sensors																
SE-11	A	A	A	A	GA	GA										
SE-17	CG	CG	CG	CG				CG			CG	CG				
SE-22	G	G	G	G	GA	G			A			G				
SE-23	G	G	G	G						A			G			
SE-30								A		A						
SE-32	H	H	H	H												
SE-33															A	
SE-38								G			A	A				
Ultrasonic Sensors																
SE-31		I	I		A	AI										
SE-37					A	A										
SE-45	CGW	CGW	CGW	CGW	CGW	CGW	CGW	CGW	CGW		CGW		CGW	CGW	CGW	CGW
Line Guide Sensors																
SE-26						G	A									
SE-46						G	A									
DAC-005	AW	AW	AW	AW	AW				AW	AW	AW	AW	AW	AW	AW	AW
Visible Light Sensors																
SE-15	G	G	G	G										G		G
SE-34	A	A	A	A												A

Matrix Legend
 A = Accuracy
 C = Center Guide
 G = General Purpose
 H = High Temperature
 I = Intrinsically Safe
 W = Width Measurement

MAXCESS®

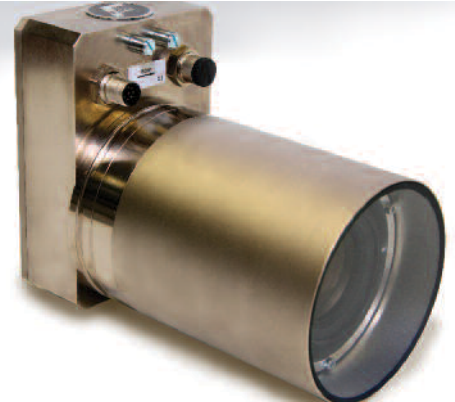

Telefono: +52 (55) 5352-0191,
Fax: +52 (55) 5561-1143
E-mail: ventas@ttemsa.mx

Técnicos en Transmisiones
Electro-Mecánicas

Santa Cruz Acayucan #165 Int 001,
Col. Santa Apolonia, Del. Azcapotzalco,
México, CDMX